Content

Chapter I Feature and Performance	- 2 -
1.1 Specifications Index.....	- 2 -
1.2 Model Definition	- 4 -
Chapter II System Installation and Debug	- 5 -
2.1 Structure	- 5 -
2.2 Installation Dimension	- 6 -
2.3 Paper Roll Installation	- 7 -
2.4 Ribbon Cassette Chang (Except Thermal Printer)	- 7 -
2.5	
2.6 Buttons and Indicators	- 8 -
Chapter III Parallel Interface Connection	- 10 -
Chapter IV : Serial Interface Connection	- 13 -
Chapter V Print command	- 18 -
Chapter VI Print Example	32
Appendix I Valid Codes Tab	35
Appendix II Index of Print Command.....	36

Chapter I Feature and Performance

1.1 Specifications Index

- ▲ Print Method: Dot matrix printer: Shuttle impact dot matrix print; Thermal printer: Direct thermal line print
- ▲ Print Speed: Normal dot matrix printer: 1.0 lines/0.7 lines/0.4 lines/sec, High speed dot matrix printer: 2.5 lines/2.7 lines/1.5 lines/1.8 lines/sec (5×7 dots character); Thermal printer : 30mm~62mm/sec.
- ▲ Resolution: Thermal printer: 8 dots/mm, 384 dots/line.
- ▲ Print width: Dot matrix printer: 33mm (44mm Paper width); Thermal printer: 48mm (57mm Paper width).
- ▲ Character per Line: Dot matrix printer: 16/24/40; Thermal printer: 32/48lines.
- ▲ Print Font: total 448 characters and graphics, including 96 ASCII characters, 352 letters of Greek, German, Russian, French etc, Japanese Katakana, partial Chinese characters, mathematics symbol, print symbols, graphic characters; 32 user-defined characters. The number of whole Chinese characters, ANK characters and graphics in GB Chinese character library level I , II is 8178.
- ▲ Character Dimension: ANK: 6×8 dots; graphic character: 6×8 dots; User-defined characters: 6×8 dots; Chinese: 24×24 dots, 16×16 dots, 12×12 dots.
- ▲ Control Order: The general print order is ESC\P, supporting forward, reverse direction, left and right rotation, reverse white, up line, underline, and left and right line print of character, Chinese character and graphic. In accordance with requirement of customer, it not only can regulate the related demand, but also carry out the function of heightening, widening, setting line spacing and character line spacing, horizontal tab, vertical tab, curve print, bar code print and mixture print of all the above.
- ▲ Print Chinese Character: Type V8, Type VS can be selected by random software to print the number, font, dots of Chinese character and through random cable downloaded to the printer. When we print Chinese character, the only operation that input corresponding Chinese character code can carry out convenient rapid print. Type 8+, type SN configures 16×16 dots GB I , II Chinese character library.
- ▲ Print Paper: Dot matrix printer: Normal paper roller with 44mm±0.5mm×ø45mm/57mm±0.5mm×ø45mm; Thermal: Thermal paper with 57mm±0.5mm×ø45mm; Suggest using print paper roller provided by Ronda technology CO. Ltd.
- ▲ Lack of Paper Test: Dot matrix printer: (optional); Thermal printer (Y/N): Y
- ▲ Printing Buffer Memory: 32K

▲ Drive: Providing WINDOWS2K/XP/NT drive programs

▲ Power Supply: Dot matrix printer: DC5V/2A; Thermal printer: DC5V/3A. According to the requirement, it can choice 7V~24V direct current.

▲ Installation Size (mm): (W xD xH) mm.

A series: Opening Size: 103x57, Appearance Size: 111x62x57.

D series: Opening Size: 103mmx57mm, Appearance Size: 114x70x64.

D II series: Opening Size: 103mmx42mm, Appearance Size: 114x70x50.

E series: Opening Size: 76mmx76mm, Appearance Size: 80x80x45.

F series: Opening Size: 128mmx90mm, Appearance Size: 128x101x75.

T series: Appearance Size: 160mmx106mmx40mm.

TH series: Appearance Size: 148mmx115mmx80mm.

▲ Operation Environment: Temperature: 0~50°C, relative humidity: 0~80%.

▲ Interface: Standard parallel interface, standard serial interface, 485interface, infrared interface (optional)

For Example: 1, Type V8, -8+, PC: Parallel (When W1 is short-circuit, it can be used as simple TTL electrical level series interface.)

2, Type VS, SN, SC: Serial interface(When W1、W2、W3 are short-circuit and taking RS232 CMOS chip, serial interface signal can be used as TTL electrical level output.)

▲ Character Set and Chinese Library Configuration:

Type V8、VS: Configure character set I , II , as well as can edit and download Chinese, characters, graphics of different dots.

Type -8+, PC, SN, SC: Configuration character set I , II , configure 16 x 16 dots, 12 x 12 dots GB Chinese library(thermistor series of 24 x 24 dots configure Chinese characters library), optionally configure 24 x 24 dots in GB level one, two Chinese Character Library.

For Example: 1, RD-E32-8+_24 configures 24x24 dots Chinese library, default printing Chinese dots: 24x24 dots and 12x24 dots character

2, RD-E32-8+-16 configures 16x16 dots Chinese library, default printing Chinese library: 32x32 dots (magnify 16x16 dots two times)

3, RD-E48 series default Chinese dot is 16x32 dots that can replace former 40 character dot-matrix printer.

1.2 Model Definition

RD	—	Body		Print Head	—	Product Number	/	Version Number					
		Appearance	Serial Number					Voltage	Interface	Dot Matrix	Slitter	requirement	—

1, RD: Stand for corporation

2, Body:

① Shape: Represented by capital English letters, such as A, D, DII, F, M, T, W, ect. An expresses panel, T e xpresses desktop, W expresses no mold.

②Serial Number: Represented by Roman numeral, such as I , II , III, etc.

3, Print Head: Represented by multi numeral and letters, such as 16, 32, 48, 150, 190G, etc.

4, Product Number: Represented by multi numeral and letters, such as V8, VS, 8+, SN, S, 485, U, H, etc.

5, Version Number: It is the product number within company that represented by multi numeral and letters, such as 5P20P -R7678.

For Example:1, RD-E32-SN_24 express that it is produced by RONGDA Technology Corporation and it's thermal, Type E, 32 character each line, serial interface, being configured 24x24 dot matrix. 2, RD-D16-8+ express that it is produced by RONGDA Technology Corporation and it's dot matrix, Type D, 16 character each line, parallel interface, being configured 16x16, 12x12 dot matrix Chinese character library.

Chapter II System Installation and Debug

2.1 Structure

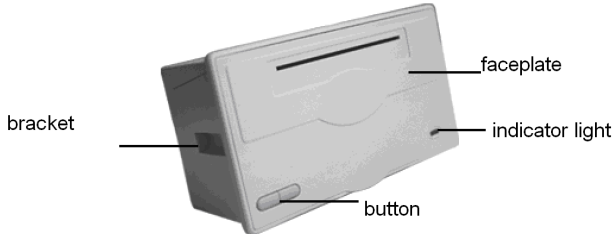

Type DII



Type D



Type E

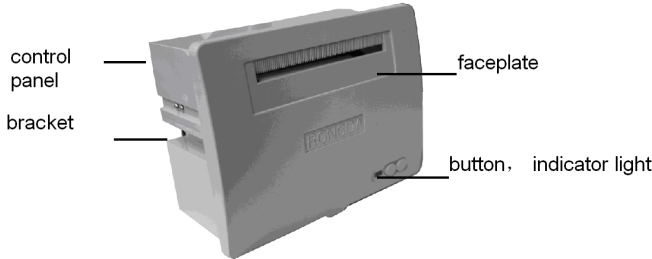

Type F

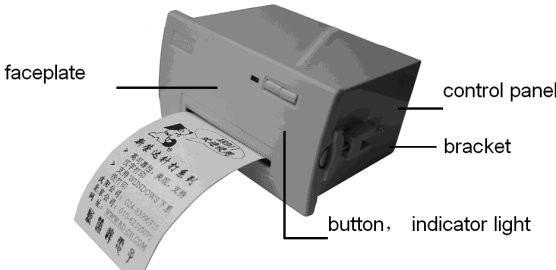

Type M

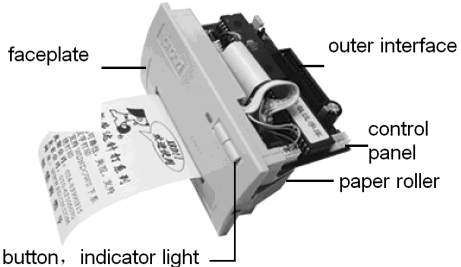

Type A



Type TH



Type T

2.2 Installation Dimension

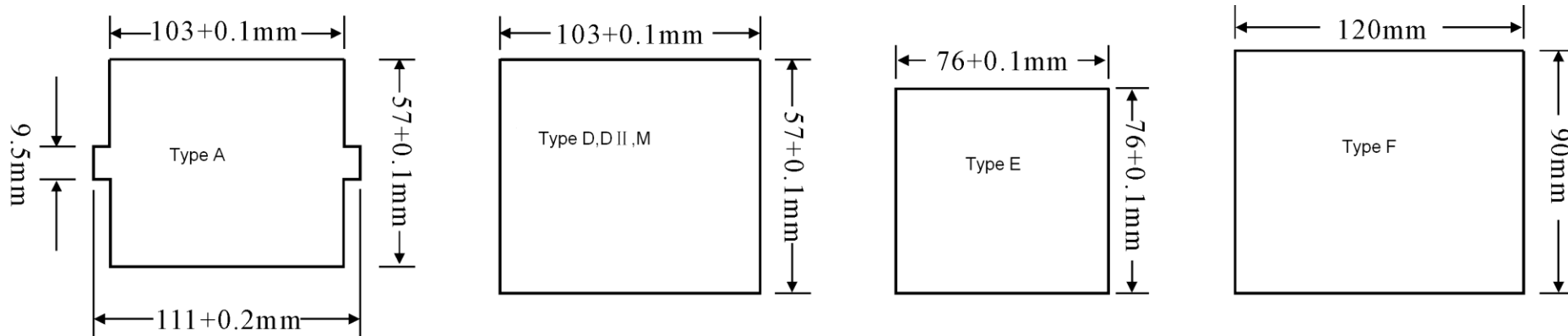

2.3 Paper Roll Installation

- 1, RD series micro printers have already been installed paper roll at ex-factory, but have not inserted paper head in the print head, this is in order to prevent the print head from damage while transport the printer for long-distance or store it for a long time, so must insert the head of the paper roll in the print head first before using the printers.
- 2, Turn on the printer's power, hold down SEL button, make the SEL indicator become dark, then press LF button to driver the print head, at this time, send the paper end into the paper slot-in which is under the print head, paper will be put into the print head quickly, until it will appear ahead of the print head, it would be better the paper shows a certain length, then press again LF or SEL button. Turn off the power, close the front cover of the printer, and make the paper come from the paper slot-out which is on the front cover.
- 3, when install the paper, the thermal side should be inwards.

2.4 Ribbon Cassette Chang (Except Thermal Printer)

- 1, The ribbon cassette has already been installed well at ex-factory, but after using for a period of time, in order to print clearer it needs to change the ribbon cassette.
- 2, Take down the ribbon. Lift up the left end of ribbon cassette first, and then lift up the right one which has the end of the knob.
- 3, Firstly put down gently the right end of new ribbon cassette on the gear wheel of printer head, lift up the left end a little, don't put down. Please hold down the knob of ribbon cassette with finger, rotate slightly to the arrow direction until the ribbon cassette has been put down to the bottom, then put down the left end.
- 4, Check whether the ribbon is straightened or exposed to outside, then rotate the button of ribbon cassette until pull the ribbon into ribbon cassette and straightened.

2.5 Power Supply Connection

RD series micro printers adopt DC +5V power supply and the permitting range of supply voltage of the dot matrix printers is $5V \pm 0.25V/2A$, the thermal is $5V \pm 0.25V/3A$.

■The plug of power cable that panel printers have offered has polarity protection mechanisms can be inserted directly in the J5 socket which is on the control panel. The red line of power cable should be connected to the positive pole (+) of power, the white line should be connected to the negative pole (-) of power.

■ The white line of power cable that desktop printers have offered should be connected to the positive pole (+) of power, the black line should be connected to the negative pole (-) of power.

Notice: The polarity of the power shouldn't be connected incorrectly, the voltage of the power must be in the permitting range, otherwise will cause permanent damage to the printer.

2.6 Buttons and Indicators

There are a green online indicator and two buttons (SEL and LF) on the panel of RD series micro printers. When the green indicator is alight, it means the print is online, contrariwise, it is offline. SEL and LF can change printer's working mode, including self-test mode, on/off line mode or paper feeding mode.

When self-test, online indicator goes dark, Busy signal line is high level and the printer can't receive the external data.

Notice: Sometime, the self-test may be incorrect, but in fact there is no matter with the printer, in this instance, please check whether the power supply adopted is qualified.

There are two kinds of method the select self-test mode, one kind of method is at any time after powered on, hold down SEL button to mark indicators become dark; another kind is that press LF button and don't release, then press SEL button at once, release the both buttons, the printer will begin the self-test. Also there is method to cancel self-test mode. The printer exits automatically after it finished printing the self-test receipt.

(2) On/offline Mode

- ① When the online indicator lights, it's online mode. BUSY signal line is low level and the printer can receive data from the host.
- ② When the online indicator is dark, it's offline mode. BUSY signal line is high level and the printer cannot receive again data from the host.

After powered on or exited self-test mode, printer goes in online mode, the online indicator lights. Hold down SEL button, indicator become dark, it goes in offline working mode, press SEL button again, re-goes in online mode.

Another function of SEL button is realizing pause during the course of printing. If hold down SEL button when the printing is going on, then release it, the printer will pause after finish printing current line. At this time, paper feeding can be selected. Hold down SEL button again and release it, the printer will continue printing.

(3) Paper Feeding Mode

When the online indicator is dark and if it needs to feed paper, hold down LF button, then release it, the printer will feed paper empty. Hold down LF button and release it again, the print will pause, hold down SEL button at this moment, the printer will restore to on-line status. Besides, it paper feeding mode can be switched on-line status directly by pressing SEL button.

Chapter III Parallel Interface Connection

RD series parallel interface which is compatible with CENTRONICS standard parallel interface can be controlled directly by micro computer parallel interface and SCM. Disconnect W1 (When W1 is short-circuit, it can be used as simple TTL- level serial interface, as explained in chapter IV).

■ The 26-pin dual socket of parallel panel is as Fig. 3-1 shows:

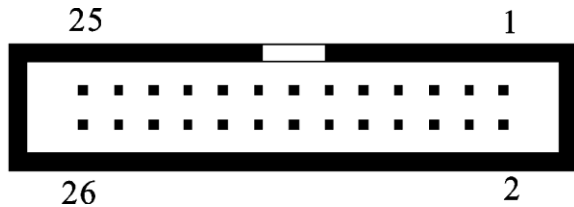

Fig.3-1

■ The DB-25-pin socket of parallel desktop is as Fig. 3-2 shows:

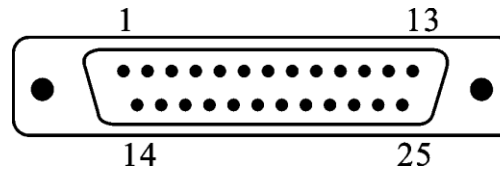

Fig.3-2

■ The timing chart for interface signal of parallel interface is as Fig.3-3 shows:

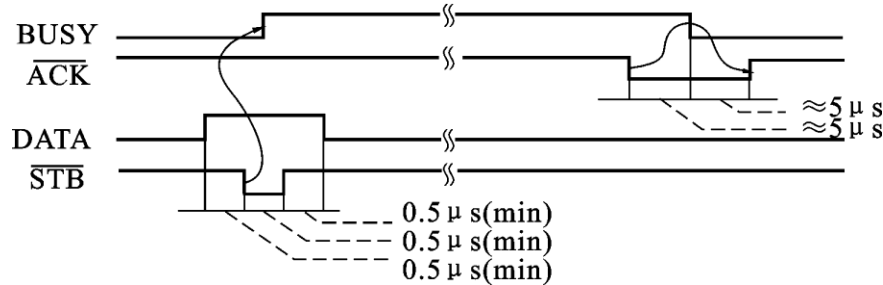

Fig.3-3

■ The Pin Signal of Parallel Interface

Pin No. (panel)	Pin No. (desktop)	Signal	Direction	Description	25-pin parallel line of PC
1	1	—STB	In	Strobe pulse to latch data, reading occurs at falling edge.	1
3	2	DATA1	In	These signals represent the 1st bit to 8th bit of the parallel data representatively, each signal is at HIGH level when data is logic1 and LOW when data is logic 0.	2
5	3	DATA2	In		3
7	4	DATA3	In		4
9	5	DATA4	In		5
11	6	DATA5	In		6
13	7	DATA6	In		7
15	8	DATA7	In		8
17	9	DATA8	In		9
19	10	—ACK	Out	Answering pulse, LOW level signal indicates that data have already been received and the printer gets ready to receive the next data.	10
21	11	BUSY	Out	HIGH level signal indicates that the printer is BUSY and can not receive data.	11
23	12	PE	— —	Grounding	— —
25	13	SEL	Out	Pulling up to HIGH level signal by resistor indicates that the printer is online.	13
4	15	—ERR	Out	Pulling up to HIGH level signal by resistor indicates that the printer has no matter.	15
2, 6, 8, 26	14~17	NC	— —	No connection	— —
10~24	18~25	GND	— —	Grounding	25, 12

Notice: (1). "In" denotes that inputs to the printer, "Out" denotes input from the printer. (2). Logical signal level is TTL

Chapter IV: Serial Interface Connection

4.1 Standard Serial Port

- DB-9 pin socket of serial panel is shown in Fig. 4-1

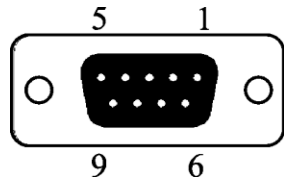

Fig. 4-1

- The 10-pin dual socket of serial panel is as Fig. 4-2 shows:

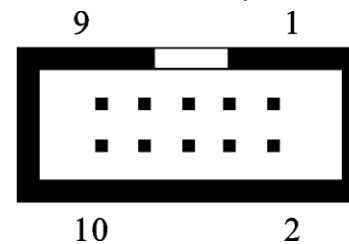

Fig. 4-2

- 5-pin socket of serial panel is shown in Fig. 4-3

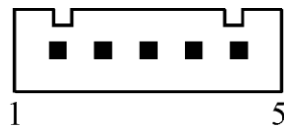

Fig. 4-3

- DB-25-pin socket of serial desktop is as Fig. 4-4 shows:

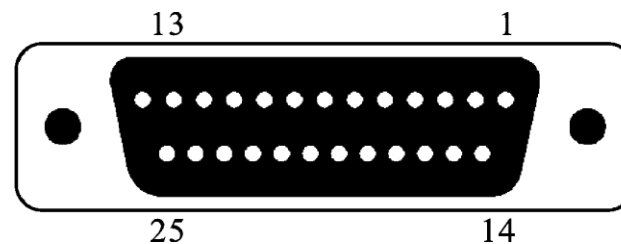

Fig. 4-4

- Notice: 1. The serial interface which is compatible with RS232C standard can be controlled by microcomputer serial interface or SCM. When W1, W2, W3 is short-circuit and take down RS232 code, output of serial interface is TTL level.
2. The choice of data rate, parity check and the way of handshaking under the method of serial connection can be done through optional 6 bit DIP switches: Band rate that have been set by DIP switch at factory is 9600BPS, the choice of

parity check is 8-Non and the handshaking is XON-XOFF.

3. When W1 is short-circuit, the parallel interface printer can be as TTL level serial interface to output. Please see chapter 4.2.

■ The Pin Signal of Serial Interface

DB-9 pin socket of serial panel	10-pin dual socket of serial pane	5-pin socket of serial panel	DB-25-pin socket of serial desktop	Signal Name	Resource	Direction	Description	DB-9 pin serial pin of PC
3	3	3	2	TXD	Host	In	Printer receives data from host	3
2	2	2	3	RXD	Printer	Out	Printer transmits control code X-ON/X-OFF to host when using X-ON/X-OFF handshaking protocol	2
8	8	—	5	CTS	Printer	Out	Signal "MARK" indicates that The printer is "BUSY "and unable to receive data; "SPACE" indicates that the printer is" READY" for receiving data.	8
6	6	—	6	DSR	Printer	Out	Signal "SPACE" indicates that the printer is "ONLINE"	6
5	5	5	7	GND	—	—	Signal Ground	5
4	4	4	8	DCD	Printer	Out	Same to signal CTS	1
7、9	7、9	—	—	NC	—	—	No Connection	4、7、9
—	—	1	—	VCC	—	—	Connect +5V Power Supply	—

Notice: (1) The "Printer" and "Host" in "Source" denote the source that signal come from; (2) Logical signal level is EIA.

■ The data structure of serial interface

Start Bit	Data Bit	Parity Bit	Stop Bit
1 bit	7 or 8 bit	1 bit	1 bit

Thereof the start bit and stop bit is both 1 bit. Data bit is 7 or 8 bits and parity bit is 1 bit. Only even parity is allowed when the data is

7 bits. The checking mode can be selected through DIP switch K5 and K6, as follow shows. It has set no parity at ex-factory, that is, K5, K6=ON, ON

■The Choice of Band Rate and Parity Check

Baud Rate Choice	Baud Rate	150	300	600	1200	2400	4800	9600	19200	
	DIP Switch	on ■■■■□□□ □□□□□□ 1 2 3 4 5 6	on □■■□□□□ ■□□□□□ 1 2 3 4 5 6	on ■□■□□□□ □■□□□□□ 1 2 3 4 5 6	on □□■□□□□ ■■□□□□□ 1 2 3 4 5 6	on ■■□□□□□ □□■□□□□ 1 2 3 4 5 6	on ■■□□□□□ □□■□□□□ 1 2 3 4 5 6	on □■□□□□□ ■□■□□□□ 1 2 3 4 5 6	on ■□□□□□□ □■□□□□□ 1 2 3 4 5 6	on □□□□□□□ ■■■□□□□ 1 2 3 4 5 6
Parity Check Choice	Check	8-Non	8-Odd	8-Even	7- Even	Handshaking Mode Selection	Handshaking Mode	Mark	XON-XOFF	At-factory Setting
	DIP Switch	on □□□□■□ □□□□□□ 1 2 3 4 5 6	on □□□□■□ □□□□■□ 1 2 3 4 5 6	on □□□□■□ □□□□■□ 1 2 3 4 5 6	on □□□□□□ □□□□■□ 1 2 3 4 5 6		DIP Switch	on □□□■□□ □□□□□□ 1 2 3 4 5 6	on □□□□□□ □□□■□□ 1 2 3 4 5 6	on ■□□■□□ □■□□□□ 1 2 3 4 5 6

The polarity of RS-232 signal in serial interface mode is:

MARK=logic "1" (EIA-3V to -27V low signal level)

SPACE=logic "0" (ELA+3V to +27V high signal level)

There are two kinds of handshaking mode for selection, one is mark control mode, another is X-ON/X-OFF protocol mode, and they can be selected by DIP switch K4, as Fig.3-6 shows. It is K4=OFF at ex-factory, the description for the two kinds of handshaking mode is as fowling shows.

Handshaking Mode	Data Direction	RS-232C Interface Signal
Mark Control	In	1 st and 8th signal line are SPAC status
	Out	1 st and 8th signal line are MARK status
X-ON/X-OFF Control	In	Send X-ON code 11H on 2 signal line

	Out	Send X-OFF code 13H on 2nd signal line
--	-----	--

The operation steps for serial interface mode are as below:

- (1) Select baud rate with DIP switch K1-K3;
- (2) Select parity checking with DIP switch K5, K6;
- (3) Select mark control or X-ON/X-OFF control handshaking mode with DIP switch K4;
- (4) When remaining 32 bytes in the data buffer, signal line DCD (1st signal line) and CTS (8th signal line) will be set to BUSY status by the printer, namely MARK status. Otherwise set to READY status, namely SPACE status;
- (5) When it is BUSY status under X-ON/X-OFF control, the printer sends X-OFF (13H) code. When READY status, it sends X-ON (11H) code;
- (6) When it is under mark control, the host sends or stops sending code string according to DCD and CTS. DCD and CTS denote READY status or BUSY status representatively.

4.2 Parallel Interface Replaces TTL Level Serial Interface

The use of parallel interface or TTL L level interface is selected by users. The method is to change the W1 short-circuit block. When W1 is short-circuit, TTL is used. When W1 is power off, parallel interface is used. Notice: It needs to power off when change the interface.

■ The 26-pin dual socket of parallel panel

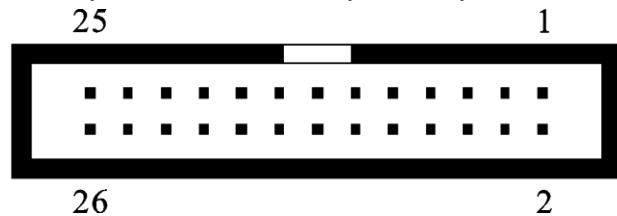

■ The DB-25-pin socket of parallel desktop

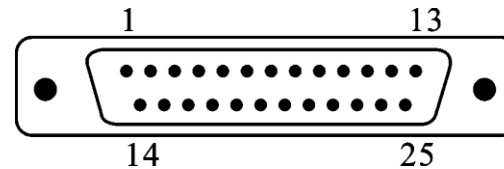

■ The Pin Signal of Parallel Interface Replacing TTL Level Serial Interface

The 26-Pin Dual Socket of Parallel Panel	The DB-25-Pin Socket of Parallel Desktop	Signal	Direction	Explanation
19	10	DATA	入	Input serial data, connect the outputted end of users' SCM
21	11	BUSY	出	"HIGH" level express that the printer is busy, so cannot receive data.
10~24	18 ~ 25	GND	—	10, 12, 14, 16, 18, 20, 24: Connect ground
2、6、8、26	—	NC	—	Disconnect
① "In" denotes that inputs to the printer, "Out" denotes input from the printer. ②. Logical signal level is TTL.				

Notice: 1, Default baud rate: 9600BPS (Special requirement, Especial setting; Work method: Mark control (Hardware floe control) ;Communication format: Serial interface connect asynchronous transfer mode format.

2, If every tine sent the data less than 20K, it can control without mark, means that connect 19 and 20 pins.

3, Data format, baud rate, parity bit, handshaking method and etc. please see chapter 4.1.

Chapter V Print command

RD series micro printer offer 39 kinds of traditional commands, they are fully compatible with majority of printer. It has added the function of Chinese character print, Chinese character rotational print, bar code print, character spacing setting and etc.

5.1 Chinese Character Print Commands

ESC 8 n [Select Different Dot-line Chinese Print Mode]

Format: ASCII: ESC 8 n

Decimal: 27 56 n

Hexadecimal: 1B 38 n

Explanation:

After printer received this command, it will choose Chinese character of different dot according to n value. Each Chinese character code that printer receive is presented by 2-byte GB code. RD series printer adopt internal code which is corresponding GB code to denote the Chinese character. Printer receives firstly the high bytes of internal code, then, receives the low bytes.

When n=0, select to print Chinese character with 16×16 dots.

When n=1, select to print Chinese character with 8×16 dots.

When n=2, select to print Chinese character with 16×8 dots.

When n=3, select to print Chinese character with 8×8 dots.

When n=4, select to print Chinese character with 12×12 dots.

When n=5, select to print Chinese character with 6×12 dots.

When n=6, select to print ASCII character with 8×16 dots.

When n=7, select to print ASCII character with 8×12 dots.

Chinese character code is standard Chinese character code:

1) The range of high-byte numerical value is A1H-F7H, corresponding 1-87 area Chinese character, calculated as follows: Area Code + A0H
2) The range of low-byte numerical value is A1H-FEH, corresponding 1-94 Chinese character bit code, calculated as follows: Bit code + A0H

For example: "荣" Characters in an area bit code is 4057, that is, area 40, No. 57 characters, the machine internal code is C8D9

Change 40(Decimal)to 28(Hexadecimal), 28H+A0H=C8H

Change 57(Decimal)to 39(Hexadecimal), 39H+A0H=D9H

When code inputted is 20H-A0H, automatically select Character Set (see Appendix I)

When code inputted is grater A0H, if the next byte is less than



A1H, it chooses international standard ASCII code, or else print Chinese character.

Notice: 1, Dot matrix printer : Default value of n is 4

2, Thermal print: ①Standard the model of 24x24 dot Chinese character library n NON 1~7 option, character is

12x24 dots ASCII code, Chinese character command is 1B 38

②Matching the default value of the model of 24x24 dot Chinese character library 16x16、12x12 is 0.

3、When configure 16x16、12x12 dots Chinese character library, (1B 38 n), appear 8x16 or 6x12 dots ASCII character.

4、The different dot Chinese character, character use to download of V series download printer, consult with download software with help of reference documents.

5、The internal code of standard Chinese character library can be download from landing on WWW.RD-CN.COM

5.2 LOG Print Command

FS L n [Log Print Command]

Format: ASCII: FS L n

Decimal: 28 118 n

Hexadecimal: 1C 76 n

Explanation:

Through software provided by our company, edit and download the graphic that users need. According to the user-defined graphic number, decide n value. The command

[HTTP://WWW.RD-CN.COM](http://WWW.RD-CN.COM)

code of printing graphics according to the order which users are downloading graphics, gives the reference, such as, user has downloaded two graphics through software provided by our company, when user need to call in print, if need print first graphic, can give reference 28 118 0, when print second graphic, give reference 28 118 1. Specific reference content can be downloaded software with the help documents and the use of software tips.

This command adopts only type V8, type VS.

5.3 Paper Feeding Commands

LF [Feed Line]

Format: ASCII: LF

Decimal: 10

Hexadecimal: 0A

Explanation:

The printer prints data in the current buffer and feeds paper forwards one line, if there is no data in the buffer, it only carries out feeding paper forward one line. One line of dot-matrix printer is 8+ line spacing. The thermal printer is 16+ line spacing.

ESC J [Carry Out n Dot Line Feed]

Format: ASCII: ESC J n

Decimal: 27 74 n

Hexadecimal: 1B 4A n

Explanation:

The printer feeds paper n dot lines. n=1~255. This command doesn't send carriage return and feed line. It won't influence the latter feed line command.

If there are data in the buffer that don't print, it will print these data before feeding paper.

ESC 1 [Set n Dot-line Spacing]

Format: ASCII: ESC 1 n

Decimal: 27 49 n

Hexadecimal: 1B 31 n

Explanation:

The line spacing is set to n dot-lines for future Line Feed command. n=0~255, default setting n=3

The BASIC programs for observing the effect of this command are as below:

```
10 FOR I=1 TO 11 STEP 2
20 LPRINT CHR$(27); "1"; CHR$(I); 'ESC 1, set
line spacing
30 LPRINT"LINE SPACING"; CHR$(10) print
character string and feed line
40 NEXT I
```

The print result of the said programs in RD-E32-V8 is as following:

```
LINE SPACING
LINE SPACING
LINE SPACING
LINE SPACING
LINE SPACING
LINE SPACING
```

ESC SP [Set character line spacing]

Format: ASCII: ESC SP n

Decimal: 27 32 n

Hexadecimal: 1B 20 n

Explanation:

Set character gap between the blank dots number, means

that finish printing a character, the printer will automatically join in the blank dots number at the right-hand of character. Character line spacing of Chinese character has been doubled. n=0~128. Default n=0.

5.4 Format Setting CommandsESC D [Set Vertical Tab Value]

Format: ASCII: ESC D n1 n2...NUL

Decimal: 27 68 n1 n2...0

Hexadecimal: 1B 44 n1 n2...000

Explanation:

The vertical tab positions are entered as n1, n2 and so on, all of these should be within the page length. Command NUL added at the end indicates the command is over. All vertical tab positions that input can be deleted by using this command in ESC D NUL format. HT command is to carry out vertical tab.

Notice: The position definition that vertical tab refers is character position of needing to print within one line. Each character of dot-matrix printer is calculated by 6+ character line spacing and the thermal printer is calculated by 12+ character line spacing.

Example: Set three vertical tab values at 2nd line, 9th line, 14th line in one page, you can send the following commands:

ASCII: ESC D STS HT SO NUL

Decimal: 27 68 2 9 14 0

Hexadecimal: 1B 44 02 09 0E 00

The BASIC programs for sending the said sequences are as below:

```
10 LPRINT"1234567890123456" 'Ruler
```



```

20 LPRINT CHR$(27); "D"; CHR$(2); CHR$(9); CHR$(14);
   CHR$(0) 'ESC D
30 LPRINT CHR$(9);           'HT command
40 LPRINT"HT1";             'Print character string
50 LPRINT CHR$(9);           'HT command
60 LPRINT"HT2";             'Print character string
70 LPRINT CHR$(9);           'HT command
80 LPRINT"HT3";             'Print character string

```

The print result in RD-E16-V8 is as following:

```

HT1   HT2   HT3
1234567890123456

```

HT [Carry out Vertical Tab Value]

Format: ASCII: HT

Decimal: 9

Hexadecimal: 09

Explanation:

The print position is advanced to the next horizontal tab position which is set by ESC D command. If there is no horizontal tab value setting, or the current position equals or is beyond the last horizontal tab position, HT command won't be carried out.

ESC f [Print Blank Characters or Lines]

Format: ASCII: ESC f M n

Decimal: 27 102 M n

Hexadecimal: 1B 66 M n

Explanation:

When m=0, ESC f NUL n will command to print n blank characters, the width of each blank is calculated by 6+ character line spacing and the value of n should be within the line width of

[HTTP://WWW.RD-CN.COM](http://www.rd-cn.com)

this model printer. When m=1, ESC f SOH n will command to print n blank lines and the height of each blank line is calculated by 6+ character line spacing. n=0~255.

Example: Print 6 blank characters in one line, you can send the following command:

ASCII: ESC f NUL ACK

Decimal: 27 102 0 6

Hexadecimal: 1B 66 00 06

Another example: print 6 blank lines, you can send the following command:

ASCII: ESC f SOH ACK

Decimal: 27 102 1 6

Hexadecimal: 1B 66 01 06

ESC Q [Set Right Margin]

Format: ASCII: ESC Q n

Decimal: 27 81 n

Hexadecimal: 1B 51 n

Explanation:

Right margin is character number that the right-hand print paper doesn't print; the width of each character is calculated by 6+ character line spacing. The value of n should be in the range from 0 to the line width of this model printer. Default n=0, that means no right margin.

This command sets absolute position, and won't be influenced by character enlarging commands ESC U and ESC W. After setting this command, the printer will carry out carriage return and feed line as long as the right margin position is reached.

Example: set right margin value to 6, you can send the



following commands:

ASCII: ESC Q ACK

Decimal: 27 81 6

Hexadecimal: 1B 51 06

The BASIC programs for this example are as below:

```
10 LPRINT"1234567890123456" 'Ruler
20 LPRINT CHR$(27); "Q"CHR$(6); 'ESC Q command
30 LPRINT"12345678901234567890"
```

The print result in RD-E32-V8 is as following:

```
1234567890
1234567890
1234567890123456
```

ESC I [Set Left Margin]

Format: ASCII: ESC I n

Decimal: 27 108 n

Hexadecimal: 1B 6C n

Explanation:

Left margin is character number that the left-hand print paper doesn't print; the width of each character is calculated by 6+ character line spacing. The value of n should be in the range from 0 to the line width of this model printer. Default n=0, that means no left margin. This command sets absolute position, and won't be influenced by character enlarging commands ESC U and ESC W.}

Example: set left margin value to 6, you can send the following commands:

ASCII: ESC I ACK

Decimal: 27 108 6

Hexadecimal: 1B 6C 06

The BASIC programs for this example are as below:

```
10 LPRINT"1234567890123456"
20 LPRINT CHR$(27); "I"; CHR$(6); 'ESC I command
30 LPRINT"12345678901234567890"
```

The print result in RD-E32-V8 is as following:

```
1234567890
1234567890
1234567890123456
```

5.5 Character Setting Commands

ESC 6 [Select Character Set I]

Format: ASCII: ESC 6

Decimal: 27 54

Hexadecimal: 1B 36

Explanation:

All characters following this command are printed using the character set I (see appendix I) that are total 224 6x8 dots character, including ASCII character, all kinds of graphic characters and etc. And the code range is 20H~FFH (32~255). There are two character sets are available in RD, character set I is selected at power on or on ESC @ command.

ESC 7 [Select Character Set II]

Format: ASCII: ESC 7

Decimal: 27 55

Hexadecimal: 1B 37

**Explanation:**

All characters following this command are printed using the character set II (see appendix I) that are 224 6x8 dots character, including German, Russian, French, Japanese Katakana and etc. The code range is 20H~FFH(32~255).

ESC U [Enlarge Width]

Format: ASCII: ESC U n

Decimal: 27 85 n

Hexadecimal: 1B 55 n

Explanation:

The characters and graphics following this command are printed at n times of normal width, n=1~8, default n=1 (dot-matrix printer), that means normal width, no width enlarging. n=0~8, default n=1 (thermal printer), that means the normal width is enlarged for twice.

The BASIC programs for observing the enlarging effect of this command are as below:

```
10 FOR I=1 TO 3                'from 3 to 5 times
20 LPRINT CHR$(27); "U"; CHR$(I) 'ESC U command
30 LPRINT"RD";                'Print character
40 NEXT I;
50 LPRINT CHR$(13)             'CR command
```

The print result in RD-E32-V8 is as following:

```
RD RD RD
```

ESC V [Enlarge Height]

Format: ASCII: ESC V n

Decimal: 27 86 n

Hexadecimal: 1B 56 n

[HTTP://WWW.RD-CN.COM](http://www.rd-cn.com)

Explanation:

The characters and graphics following this command are printed at n times of normal height, n=1~8, default n=1 (dot-matrix printer), that means no height enlarging. n=0~8, default n=1 (thermal printer), that means the normal height is enlarged for twice. This command should be sent at the beginning of one line.

The BASIC programs for observing the enlarging effect of ESC V command are as below:

```
10 FOR I=1 TO 3;                ' from 1 to 3 times
20 LPRINT CHR$(27); (V); CHR$(I); 'ESC V command
30 LPRINT"RD"                  'Print command
40 NEXT I
```

The print result in RD-E32-V8 is as following:

```
RD
RD
RD
```

ESC W [Enlarge Width and Height]

Format: ASCII: ESC W n

Decimal: 27 87 n

Hexadecimal: 1B 57 n

Explanation:

The characters and graphics following this command are printed at n times of normal width and height, n=1~8, default n=1 (dot-matrix printer), that means no width and height enlarging. n=0~8, default n=1 (thermal printer), that means the normal width and height are enlarged for twice.



The BASIC programs for observing the print effect of this command are below:

```
10 FOR I=1 TO 3;           'From 1 to 3 times
20 LPRINT CHR$(27); "W"; CHR$(I)
30 LPRINT"RD"             'Print character string
40 NEXT I
```

The print result in RD-E32-V8 is as following:

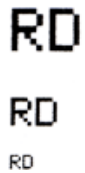

ESC X [Enlarge Width and Height for Different Times]

Format: ASCII: ESC X n1 n2
 Decimal: 27 88 n1 n2
 Hexadecimal: 1B 58 n1 n2

Explanation:

The characters following this command are printed at n1 times of normal width and at n2 times of normal height. n1, n2= 1~8, default n1=n2=1, that means no width and height enlarging.

ESC r [Thermal Print Depth regulation]

Format: ASCII: ESC r 2B/2D n
 Decimal: 27 114 43/45 n
 Hexadecimal: 1B 72 2B/2D n

Explanation:

n = 0 ~15

When select 1B 72 2B n to enhance the depth regulation, the greater the value of n, the deeper the print depth.

When select 1B 72 2D n to reduce the depth regulation, the greater the value of n, the shallower the print depth.

Restore command is 1B 72 2D 0 or 1B 72 2B 0.

Notice: Users can regulate the print depth according to the actual situation, when regulate shallower, it will reduce printer's power, when increase depth, power will increase.

SO [Set Double Width Character Print within One Line]

Format: ASCII: SO
 Decimal: 14
 Hexadecimal: 0E

Explanation:

All characters following this command on the same line are printed at twice their normal width. This command can be deleted by a carriage return or DC4 command.

Normal characters and width-enlarged characters can be printed on the same line.

DC4 [Cancel Double Width Character Print within One Line]

Format: ASCII: DC4
 Decimal: 20
 Hexadecimal: 14

Explanation:

Double width print mode that is set by SO command can be



canceled by DC4 command. This command doesn't cancel width enlarging print which set by ESC U and ESC W.

ESC — [Select/cancel Underline Print]

Format: ASCII: ESC — n

Decimal: 27 45 n

Hexadecimal: 1B 2D n

Explanation:

When n=1, select underline print; when n=0, cancel underline print. After power on or restoring the position n=0. All characters and Chinese characters including spaces will be printed out with underline after selecting underline print command, unless cancel the underline print command.

The BASIC programs for observing the effect of this command are as below:

```
10 LPRINT CHR$(27); "W"; CHR$(2);
```

```
20 LPRINT"RD"
```

```
30 LPRINT CHR$(27); "—"; CHR $(1); 'Select
```

underline print

```
40 LPRINT"UPT" 'UPT print
```

with underline

```
50 LPRINT CHR$(27); "+"; CHR $(0); Cancel
```

underline print

```
60 LPRINT "RD"
```

The print result in RD-A16-V8 is as following:

RDUPTRD

ESC + [Select/cancel Up-line Print]

Format: ASCII: ESC + n

Decimal: 27 43 n

[HTTP://WWW.RD-CN.COM](http://www.rd-cn.com)

Hexadecimal: 1B 2B n

Explanation:

When n=1, select up-line print; when n=0, cancel up-line print. After power on or restoring the position n=0. All characters and Chinese characters including spaces will be printed out with up-line after selecting up-line print command, unless cancel the up-line print command.

The BASIC program for observing the effect of this command are as below:

```
10 LPRINT CHR$(27); "W"; CHR$(2)
```

```
20 LPRINT"RD"
```

```
30 LPRINT CHR$(27); "+"; CHR$(1); 'Select
```

underline print

```
40 LPRINT"UPT"; 'UPT print
```

with underline

```
50 LPRINT CHR$(27); "+"; CHR$(0);
```

```
60 LPRINT"RD"
```

The print result in RD-E32-V8 is as following:

RDUPTRD

FS r [Select Up and under Superscript and Subscript]

Format: ASCII: FS r n

Decimal: 28 114 n

Hexadecimal: 1C 72 n

Explanation:

This command can choose the position of superscript and subscript. When n=0, it is superscript. When n=1, it is subscript. The superscript (subscript) means that this character and the largest character is upper (lower) alignment when a character



height is less than the largest character height of current line.

ESC i _____ [Select/cancel Reverse White Print]

Format: ASCII: ESC i n
 Decimal: 27 105 n
 Hexadecimal: 1B 69 n

Explanation:

When n=1, select reverse white print; when n=0, cancel reverse white print. Reverse white print is printing in the black background. It is normal print that printing black characters in white background.

When the last character of a line is reverse white character, the blank between current line and next line is filled in the black line. After power on or restoring the position n=0. The BASIC programs for reverse white print are as below:

```
10 LPRINT CHR$(27); "i"; CHR$(1)
20 LPRINT"ABCDEFGHIJKLMNO"
```

The print result in RD-E32-V8 is as following:



ESC C _____ [Select/cancel Reverse Print]

Format: ASCII: ESC C n
 Decimal: 27 99 n
 Hexadecimal: 1B 63 n

Explanation:

When n=1, select reverse print; when n=0, cancel reverse print. Print direction is from left to right. Usually reverse print is adopted when printers are installed vertically, so as to observe the print result. When power on and restoring the position, default n=1.

Reverse print not only supports character mode but also supports graphics mode. When print the graphics in reverse direction, pay attention to the print order of graphic units, please see ESC K command.

FS J _____ [Set Vertical Print]

Format: ASCII: FS J
 Decimal: 28 74
 Hexadecimal: 1C 4A

Explanation:

This command is to set left-rotation character named vertical print. Print direction is from left to right.

FS K _____ [Set Horizontal Print]

Format: ASCII: FS K
 Decimal: 28 75
 Hexadecimal: 1C 4B

Explanation:

This command is to set obverse character named horizontal print. Print direction is from left to right.

FS 2 _____ [Set Chinese Character Rotational Print]

Format: ASCII: FS 2 n
 Decimal: 28 73 n
 Hexadecimal: 1C 49 n

Explanation: This command is to rotate Chinese characters, the values of n are as following:

n	Chinese characters	Print direction
	rotated	



	widdershins	
0	0°	From left to right
1	90°	From left to right
2	180°	From right to left
3	270°	From right to left

5.6 User-defined Character Setting Commands

ESC & [User-defined Characters]

Format: ASCII: ESC & m n1 n2...n6

Decimal: 27 38 m n1 n2...n6

Hexadecimal: 1B 26 m n1 n2...n6

Explanation:

This command allows a character to be defined, parameter m is the code of user-defined character, m=32~255. Parameter n1, n2, ...n6 are the structure codes of user-defined character. The character size is 6 × 8 dots. Each row is denoted by one byte data, the MSB is on the top, as the below figure shows:

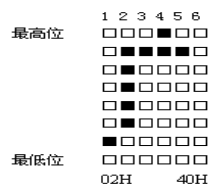

n1=02H, n2=7CH, n3=40H, n4=COH, n5=40H, n6=0H

The user-defined characters are stored in printer RAM until power off. If many ESC U commands use same m value, only the last one is valid. User can define at most 32 characters.

ESC % [Replace with User-defined Characters]

Format: ASCII: ESC % m1 n1 m2 n2...mk nk

NUL

Decimal: 27 37 m1 n1 m2 n2...mk nk 0

Hexadecimal: 1B 25 m1 n1 m2 n2...mk nk 0

Explanation:

This command is used to replace the character n with the user-defined character m, and the user-defined character m will be printed out as the replacement of character n.

m1, m2.....mk are the codes of user-defined characters.

n1, n2.....nk are codes of characters in the current character set – the replaced characters.

The values of m and n both should be in the range 32 to 255.

The subscript K=1~32, the maximum number of replaced characters is 32.

Character NUL added to the end means the command is over.

ESC : [Restore Characters that in Character Set]

Format: ASCII: ESC :

Decimal: 27 58

Hexadecimal: 1B 3A

Explanation:

This command is used to restore the original characters in the character set replaced by user-defined characters using ESC % command. However, user-defined characters won't be deleted from the RAM in printer and may brought back



again with ESC % command.

The BASIC programs for observing the effect of ESC &, ESC % and ESC : are as below:

```

10 LPRINT CHR% (27): "W"; CHR$(2);      'Enlarge width
and height 2 times
20 LPRINT CHR$ (27); "&"; CHR$ (65);      'ESC &
command
30 LPRINT CHR$ (&H02); CHR$ (&H7C); CHR$ (&H40);
40 PRIINT CHR$ (&HC0); CHR$ (&H40); CHR$ (&H00);
50 LPRINT CHR$ (27); "%"; CHR$ (65); CHR$ (65);
CHR$ (0); 'ESC %
60 LPRINT CHR $ (65);                      'Print
user-defined characters
70 LPRINT CHR $ (27); ": ";                'ESC: Command
80 LPRINT CHR $(65);                       'Restore characters
in the character set

```

The print result in RD-E32-V8 is as following:



5.7 Graphics Print Commands

ESC K [Print bit-map graphics]

Format: ASCII: ESC K n1 n2 ...data...

Decimal: 27 75 n1 n2 ...data...

Hexadecimal: 1B 4B n1 n2 ...data...

Explanation:

This command is used to print n1x8 bit map. The width of this graphics is n1 and the height is 8 dots. Each column has 8 dots and can be presented by an 8-bit byte; the MSB is on the top.

The values of n1, n2 denote a 16-bit binary data, n1 is LSB, n2 is MSB, n2 x256 + n1 denotes the width of this printing graphics. n2 =0 or 1, the sum of dots number should be ≤384, if the excess will automatically remove. n1 should be in the range from 1 to the max.

Data are the bytes of relative columns in the graphics sequential from left to right. The number of bytes should equal n1.

When the height of the graphics is larger than 8 dots, it can be marked off several units according to 8 dot lines for each graphic unit, when the dots are fewer than 8, use blank dots to make up it, then print out every graphic unit with ESC K command orderly, at last compose an intact graphics.

Notice: when adopting reverse print mode, you should print every graphic unit sequentially according to the order from top to bottom of the graphics. For example: If you want to print two Chinese characters “中文” with ESCK command, the bit-map for the two Chinese is as the below figure shows. Each character is composed by 7 x 8 dots to 7 columns, there is a space between the two characters, so totally there are 15 columns, then n1=15,n2=0, the 15-byte data showed in hexadecimal are as follows:

7CH, 44H, 44H, FFH, 44H, 44H, 7CH, 00H, 41H, 62H, 54H, C8H, 54H, 62H, 41H

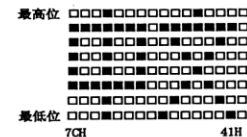

The BASIC programs for this example are as below:



```

10 LPRINT CHR$(27); "W"; CHR$(2);      'Enlarge the
width and height 2 times
20 LPRINT CHR$(27); "K"; CHR$(15); CHR$(0); 'ESC
K command
30 FOR I=1 TO 15
40 READ D : LPRINT CHR$(D)           'Input 15-byte
data
50 NEXT I
60 LPRINT CHR$(13)                   'Input CR
70 DATA &H7C, &H44, &H44, &HFF, &H44, &H44, &H7C,
0
DATA &H41, &H62, &H54, &HC8, &H54, &H62, &H41

```

The print result in RD-E32-V8 is as following:

中文

```

ESC ' [ Print Curve I ]
Format: ASCII: ESC ' m n1 n2...nk CR
Decimal: 27 39 m n1 n2 ...nk 13
Hexadecimal: 1B 27 m n1 n2 ...nk 0D

```

Explanation:

This command is designed to print curving graphics along with the paper feeding direction. The value of m is the line number of the printing curve. It should be within the range of the maximal dots number of each line of this model printer. There are m curving dots in one horizontal line. n1, n2.... nk denote the position of m curves. The value of nk should equal m and each nk should be within the range of the maximal dots number of each line of this model printer. The

[HTTP://WWW.RD-CN.COM](http://www.rd-cn.com)

last CR (Carriage Return) lets the printer print out the current dot line, so a set of dot lines will be printed out form m-line curving graphics based on the data of n1, n2.... Nk. Continuous use of this order may be printed out arbitrary length of the curve.

Notice: This command adopts only dot-matrix printers and parts of thermal printers.

For example: If you want to print the following 5 equational curving graphics:

$$Y1=50+40*EXP(-0.01*X)*SIN(X/10)$$

$$Y2=50-40*EXP(-0.01*X)*SIN(X/10)$$

$$Y3=50$$

$$Y4=50+40*EXP(-0.1*X)$$

$$Y5=50-40*EXP(-0.01*X)$$

You can program the following programs with BASIC language:

```

10 FOR X =0 TO 150                      'Print 150
dot lines
20 Y=INT(40*EXP(-0.01*X))
30 YY=INT(Y*SIN(X/10))
40 LPRINT CHR$(27); CHR$(39); CHR$(5); 'ESC
command, m=5
50 LPRINT CHR$(50+YY); CHR$(50-YY); CHR$(50);
60 LPRINT CHR$(50+Y); CHR$(50-Y); CHR$(13);
70 NEXT X

```

The print result for these programs in RD-E32-V8 is as following:

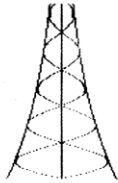
ESC ' [Print Curve II]

Format: ASCII: ESC ' m Low m High n1 Low n1
High.....nk Low nk High CR
Decimal: 27 39 m Low m High n1 Low n1
High.....nk Low nk High 13
Hexadecimal: 1B 27 m Low m High n1 Low n1
High.....nk Low nk High 0D

Explanation:

n1Low, n1High denote the position of m curves. n1 Low is n1 dot's LSB, n1 High is n1 dot's MSB. The value of m is the line number of the printing curve. It should be within the range of the maximal dots number of each line of this model printer.

There are m curving dots in one horizontal line. n1, n2.... nk denote the position of m curves. The value of nk should equal m and each nk should be within the range of the maximal dots number of each line of this model printer. The last CR (Carriage Return) lets the printer print out the current dot line, so a set of dot lines will be printed out form m-line curving graphics based on the data of n1, n2.... Nk.

Continuous use of this order may be printed out arbitrary length of the curve.

Notice: This command adopts only dot-matrix printers and parts of thermal printers.

ESC E [Print Bar Code]

Format: ASCII: ESC E nq nc n1 n2 n3...nk NUL
Decimal: 27 69 nq nc n1 n2 n3...nk 0
Hexadecimal: 1B 45 nq nc n1 n2 n3...nk 00

Explanation:

nq: The first line of bar code from the end of the distance, n=0~64.

nc: The height dot of bar code, n=1~255.

nk: The parameter of kth. Bar code line:

The blank dot number of high 4-bit (D7~D4) and the previous bar code line, n==1~15.

The height of this low 4-bit (D3~D0, K is the number of bar code, k 1~15.

Notice: This command adopts only thermal printers.

5.8 Initialization CommandsESC @ [Initialize Printer]

Format: ASCII: ESC @
Decimal: 27 64
Hexadecimal: 1B 4

Explanation: After this command, the printers restore the default.

5.9 Data Control CommandsCR [Carriage Return]

Format: ASCII: CR
Decimal: 13
Hexadecimal: 0D

Explanation:

After the printer receive command; it deals with the order and

[HTTP://WWW.RD-CN.COM](http://www.rd-cn.com)



character in the buffer, as required, print the total character or Chinese character in the buffer.

Notice: The function of combinatorial order of carriage return and feed line command is same to the signal order.

NUL [NUL]

Format: ASCII: NUL

Decimal: 0

Hexadecimal: 00

Explanation:

NUL command is used as the final code in some commands such as ESC B, ESC D, ESC % and ECS ', denotes these commands are over. NUL command is ignored when used alone.

Chapter VI Print Example

It's controlled to print by 51 assembler language through MCS-51 SCM serial and parallel port

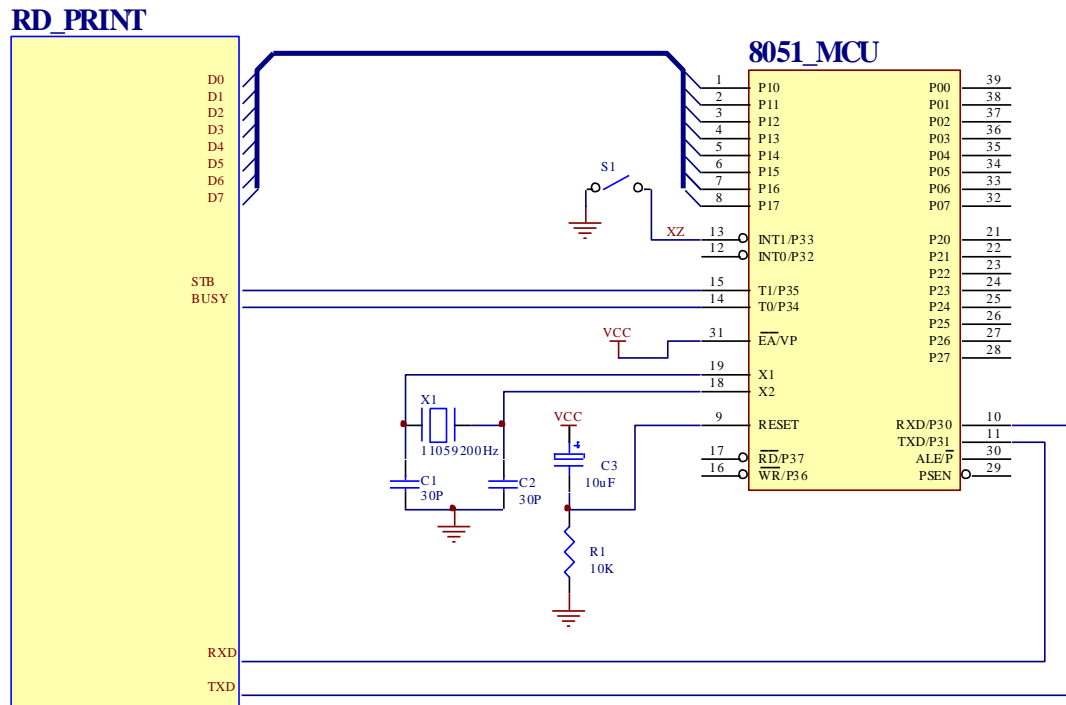

- ; RXD, TXD, CTS (BUSY) of RS232 serial printer is RS232 logical level.
- ; P1 port connect D0-D7 of the printer
- BUSY EQU P3.4 ; Parallel printer 'BUSY, serial printer' CTS



```

    STB    EQU    P3.5      ; Printer STB connect P3.5
    XZ     EQU    P3.3      ; The choice of serial or parallel port is serial output.
    ORG    0000H
    JMP    INIT
    ORG    0030H
; ----- Initializing serial interface -----
INIT: MOV   TH1,    #253      ; Baud 9600 Crystal Oscillator 11.0592MHZ
      MOV   TMOD,  #00100000B ; Serial Port Setting , Timer 1, Setting Method 2
      MOV   SCON,  #11010000B ; Serial Sending Method 3
; ----- Main Program output a set of data circularly, the first address is TAB-----
MAIN: MOV   DPTR,  #TAB      ; The first address of outputting data is TAB.
M3:  CLR   A
      MOV   A,    @A+DPTR
      INC   DPTR
      CJNE  A,    #0FFH, M2   ; When the data is 0FFH, MAIN output data circularly.
      JMP   MAIN
M2:  CALL  OUT_1BYTE        ; Output one-byte
      JMP   M3
; -----Output one-byte data to the subprogram of printer -----
OUT_1BYTE:
      SETB  BUSY
      JB   BUSY, OUT_1BYTE    ; If BUSY is 1, it indicates the printer is busy, waiting .
      JNB  XZ, LPT           ; When XZ is 1, serial port outputs, when is 0, parallel port output.
; -----Data output by serial port-----
      MOV  SBUF,  A
      JNB  TI, $             ; Wait for accomplishment of sending data.
      CLR  TI
      RET                    ; Accomplish outputting the serial port one-byte.
; ----- Data output by parallel port -----
```



```

LPT: MOV P1, A ; P1 port connects data wire of printer.
      CLR STB ; Output the optional signal STB, more than one microsecond
      NOP
      NOP
      SETB STB
      RET ; Accomplish outputting the parallel port one-byte
; ----- Data output to the printer-----
TAB: DB '1','2','3','4','5','6','7','8','9','A'
      DB 13
      DB 1BH,38H,0H,'荣','达','电','子',1BH,36H
      DB 'A','B','C','D','E','F',1BH, 38H, 04H
      DB '热','敏','针','打','系','列','0DH'
      DB 0FFH
      END

```

Notice: The Chinese character can be printed out through searching the machine code of Chinese counterparts; also can be directly input Chinese character in assembler or high-level characters in code automatically through the compiler.



Appendix I Valid Codes Tab

Character Set I

	0	1	2	3	4	5	6	7	8	9	A	B	C	D	E	F
2	!	"	#	\$	%	&	'	()	*	+	,	-	.	/	
3	0	1	2	3	4	5	6	7	8	9	:	;	<	=	>	?
4	@	A	B	C	D	E	F	G	H	I	J	K	L	M	N	O
5	P	Q	R	S	T	U	V	W	X	Y	Z	[\]	↑	←
6	`	a	b	c	d	e	f	g	h	i	j	k	l	m	n	o
7	p	q	r	s	t	u	v	w	x	y	z	{		}	~	Δ
8	0	-	二	三	四	五	六	七	八	九	十	元	角	分	月	日
9	£	¢	↓	→	^	±	÷	∞	≈	∞	0	0	2	3	2	3
A	α	β	γ	δ	ε	ζ	η	θ	ι	κ	λ	μ	ν	ξ	π	ρ
B	τ	ψ	φ	ω	Γ	Δ	Σ	Ψ	Ω	Θ	Φ	Π	Λ	Χ	Ψ	Ζ
C	□	□	□	□	□	□	□	□	□	□	□	□	□	□	□	□
D	□	□	□	□	□	□	□	□	□	□	□	□	□	□	□	□
E	α	β	γ	δ	ε	ζ	η	θ	ι	κ	λ	μ	ν	ξ	π	ρ
F	α	β	γ	δ	ε	ζ	η	θ	ι	κ	λ	μ	ν	ξ	π	ρ

Character Set II

	0	1	2	3	4	5	6	7	8	9	A	B	C	D	E	F
2	百	千	万	元	角	分	'	4	4	4	4	4	4	4	4	4
3	#		U	Π	Θ	C	コ	€	€	¥	¥	¥	¥	¥	¥	¥
4	∴	≡	≡	≡	≡	≡	≡	≡	≡	≡	≡	≡	≡	≡	≡	≡
5	*	※	()	《	》	『	』	『	』	『	』	『	』	『	』
6	♠	♠	♠	♠	♠	♠	♠	♠	♠	♠	♠	♠	♠	♠	♠	♠
7	夕	夕	夕	夕	夕	夕	夕	夕	夕	夕	夕	夕	夕	夕	夕	夕
8	々	々	々	々	々	々	々	々	々	々	々	々	々	々	々	々
9	ン	ア	ウ	エ	オ	カ	キ	ク	ケ	コ	ク	ケ	コ	ク	ケ	コ
A	ハ	ヘ	ヒ	フ	フ	フ	フ	フ	フ	フ	フ	フ	フ	フ	フ	フ
B	ウ	ウ	ウ	ウ	ウ	ウ	ウ	ウ	ウ	ウ	ウ	ウ	ウ	ウ	ウ	ウ
C	ウ	ウ	ウ	ウ	ウ	ウ	ウ	ウ	ウ	ウ	ウ	ウ	ウ	ウ	ウ	ウ
D	ウ	ウ	ウ	ウ	ウ	ウ	ウ	ウ	ウ	ウ	ウ	ウ	ウ	ウ	ウ	ウ
E	ウ	ウ	ウ	ウ	ウ	ウ	ウ	ウ	ウ	ウ	ウ	ウ	ウ	ウ	ウ	ウ
F	ウ	ウ	ウ	ウ	ウ	ウ	ウ	ウ	ウ	ウ	ウ	ウ	ウ	ウ	ウ	ウ

GB ASCII Codes Tab

	0	1	2	3	4	5	6	7	8	9	A	B	C	D	E	F
2	!	"	#	\$	%	&	'	()	*	+	,	-	.	/	
3	0	1	2	3	4	5	6	7	8	9	:	;	<	=	>	?
4	@	A	B	C	D	E	F	G	H	I	J	K	L	M	N	O
5	P	Q	R	S	T	U	V	W	X	Y	Z	[\]	^	_
6	`	a	b	c	d	e	f	g	h	i	j	k	l	m	n	o
7	p	q	r	s	t	u	v	w	x	y	z	{		}	~	Δ
8	Ç	ü	é	â	ä	à	å	é	ë	è	ï	î	ï	Ä	Å	
9	É	æ	Æ	ô	ö	ò	û	ù	ÿ	Ö	Ü	ç	£	¥	℞	f
A	á	í	ó	ú	ñ	Ñ	º	º	º	º	º	º	º	º	º	º
B																
C	L	L	T	T	T	T	T	T	T	T	T	T	T	T	T	T
D																
E	α	β	γ	π	Σ	σ	μ	γ	θ	Ω	δ	ω	φ	€	Π	
F	≡	±	≥	≤	∫	∫	∫	∫	∫	∫	∫	∫	∫	∫	∫	∫



Appendix II Index of Print Command



Decimal	Hexadecimal	ASCII	Function
0	00	NUL	Ending Symbol
9	09	HT	Carry Out Horizontal Tab
10	0A	LF	Feed Line
11	0B	VT	Carry Out Vertical Tab
13	0D	CR	Carriage Return
14	0E	SO	Set Double Width Character Print
20	14	DC4	Cancel SO command
27 32	1B 20	ESC SP n	Set Character Line spacing
27 37	1B 25	ESC 'm LOW M HIGH n1 LOW n1 HIGH.....nk LOW nk HIGH CR	Print Curve
27 38	1B 26	ESC & m n1 n2...n6	User-defined
27 39	1B 27	ESC % m1 n1 m2 n2...mk nk NUL	Replace User-defined
27 43	1B 2B	ESC + n	Select/cancel Up-line Print
27 45	1B 2D	ESC - n	Select/cancel Underline Print
27 49	1B 31	ESC 1 n	Set line spacing to n dot lines



RD series micro printer user manual

27 54	1B 36	ESC 6	Select character set I
27 55	1B 37	ESC 7	Select character set II
27 56	1B 38	ESC 8 n	Select different dot matrix Chinese print
27 58	1B 3A	ESC :	Restore Font Character
27 64	1B 40	ESC @	Initialize printer
Decimal	Hexadecimal	ASCII	Function
27 68	1B 44	ESC D n1 n2 n3...NUL	Set horizontal tab
27 69	1B 45	ESC E nq nc n1 n2 n3 ...nk NUL	Print bar code
27 74	1B 4A	ESC J n	Feed line n dot lines
27 75	1B 4B	ESC K n1 n2...data...	Print n1x8 bit-map graphics
27 81	1B 51	ESC Q n	Set right margin width
27 85	1B 55	ESC U n	Enlarge width n times
27 86	1B 56	ESC V n	Enlarge height n times
27 87	1B 57	ESC W n	Enlarge width and height n times
27 88	1B 58	ESC X n1 n2	Enlarge width and height different times



27 99	1B 63	ESC C n	Select/cancel reverse print
27 102	1B 66	ESC f M n	Print blank or feed line
27 105	1B 69	ESC i n	Select/cancel reverse white print
27 108	1B 6C	ESC l n	Set left margin width
27 114	1B 72	ESC r n/2b/2d n	Thermal Print Depth regulation
28 73	1C 49	FS 2 n	Set Chinese Character Rotational Print
28 74	1C 4A	FS J	Set Vertical Print
28 75	1C 4B	FS K	Set Horizontal Print
28 114	1C 72	FS r n	Select Up and under Superscript and Subscript
28 118	1C 76	FS L	LOG print command
28 119	1C 77	FS M 1 data...0	Subscribe print command