

L/S® PTFE-TUBING PUMP HEAD

FEATURES/BENEFITS

- ▶ Flow range: 0.06 to 65 mL/min
- ▶ Transfer aggressive organic solvents and maintain fluid purity
- ▶ Transfer liquid containing small particulates
- ▶ Excellent chemical compatibility
- ▶ Deliver a wide range of flow rates at pressures up to 100 psi
- ▶ Adjustable occlusion
- ▶ Use precision-molded tubing sets

SELECTION CRITERIA

- ▶ Flow rate desired.
- ▶ Tube size required.
- ▶ Compatibility with drives.

See specifications for more information.

Order tubing and drives separately.

COMPATIBILITY WITH DRIVES

- ▶ Mount on all Masterflex L/S drives that accept two or more pump heads

PUMP HOUSING SPECIFICATIONS

- ▶ Pump body, bearing support, and rotor plates are anodized aluminum
- ▶ Rotor shaft, bearing, rollers, and hardware are stainless steel
- ▶ Occlusion bed: acetal
- ▶ ABS plastic occlusion knob

NOTES

Use only Masterflex PTFE-tubing sets with the Masterflex PTFE-tubing pump head to ensure optimal performance. Use of other tubing may void applicable warranties.

ROLLER/ROTOR SPECIFICATIONS

300-Series Stainless Steel (SS)

- ▶ Humidity from 0% to 100%
- ▶ Operating temperature from 0 to 40°C (32 to 104°F)
- ▶ Fluid temperature from 0 to 100°C (32 to 212°F)
- ▶ Ball-bearing construction
- ▶ Continuous duty up to 300 rpm



PTFE-tubing pump head 77390-00



PTFE tubing pump head 77390-00 shown on L/S variable-speed console drive 07528-20 is ideal for transferring aggressive organic solvents.

ISO 9001:2008
CERTIFIED SUPPLIER

2 year
warranty

ORDERING INFORMATION

Catalog number	Description
HL-77390-00	L/S PTFE-tubing pump head only

PTFE-TUBING SETS AND ACCESSORIES

PTFE-Tubing Sets include two 38 cm (15") lengths and cannot be substituted with ordinary PTFE tubing. Choose compression fittings below to adapt tubing sets to your system.

[HL-77390-50](#) PTFE-tubing set, 4-mm OD, 2-mm ID. Set of two 38-m (15") lengths.

[HL-77390-60](#) PTFE-tubing set, 6-mm OD, 4-mm ID. Set of two 38-m (15") lengths.

For 4-mm OD PTFE-Tubing Sets

[HL-31321-61](#) Straight connector, 2.8 bar (40 psi) max pressure

[HL-31321-62](#) Male pipe adapter with 1/8" NPT(M) connection

[HL-31321-63](#) Male pipe adapter with 1/4" NPT(M) connection

[HL-06605-53](#) PTFE extension tubing, 4-mm OD. Pack of 7.6 m (25 ft)

For 6-mm OD PTFE-Tubing Sets

[HL-31321-64](#) Straight connector, 9.2 bar (135 psi) max pressure

[HL-31321-43](#) Male pipe adapter with 1/4" NPT(M) connection

[HL-06605-54](#) PTFE extension tubing, 6-mm OD. Pack of 7.6 m (25 ft)

[HL-31321-49](#) Tubing grooving tool. Use when connections must withstand 40 psi (2.8 bar) or greater



PTFE tubing sets, PTFE extension tubing, and straight connectors.



SPECIFICATIONS for L/S PTFE-Tubing Pump Head

Catalog number		HL-77390-00
Performance Specifications		
Flow capacity	4-mm OD tubing	0.06 to 17 mL/min (0 to 0.27 GPH)
	6-mm OD tubing	0.25 to 65 mL/min (0 to 1.1 GPH)
Max rpm	300	
Number of rollers	6	
Vacuum lift	2.4 m H ₂ O (8 ft H ₂ O)	
Maximum Torque [pumping water at 0 psi, 21°C (70°)]		
PTFE tubing	12.9 kg-cm (180 oz-in)	
Physical Specifications		
Pump body, bearing support, and rotor plates material	Anodized aluminum	
Rotor shaft, bearings, rollers, and hardware material	Stainless steel	
Reversible	Yes	
Run dry	No [†]	
Operating temperature	0 to 40°C (32 to 104°F)	
Shipping weight	1.5 kg (3.3 lb)	

[†]Do not pump gases or run dry for long periods of time; run dry to prime only.

COMPLETE L/S PTFE-TUBING PUMP SYSTEM

Applications

- ▶ Pumping high-purity fluids
- ▶ Transfer of aggressive chemicals
- ▶ Chemical feed and metering
- ▶ Filtration

Benefits

- ▶ Flow rate: 0.75 to 65 mL/min; pressure up to 100 psi (6.9 bar)
- ▶ Low-pulsation, six-roller pump head
- ▶ Continuous-duty drive displays speed (rpm) and direction

Complete system includes: L/S PTFE tubing pump head 77390-00, 6-mm OD PTFE tube set 77390-60, L/S 300 rpm variable-speed console drive 07528-20, and two ¼" NPT(M) pipe adapters.



Catalog number	Power
HL-77912-10	90 to 260 VAC, 50/60 Hz

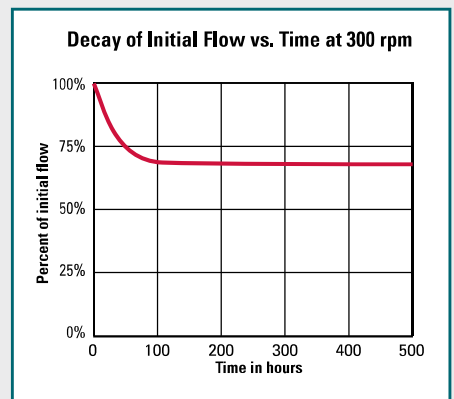
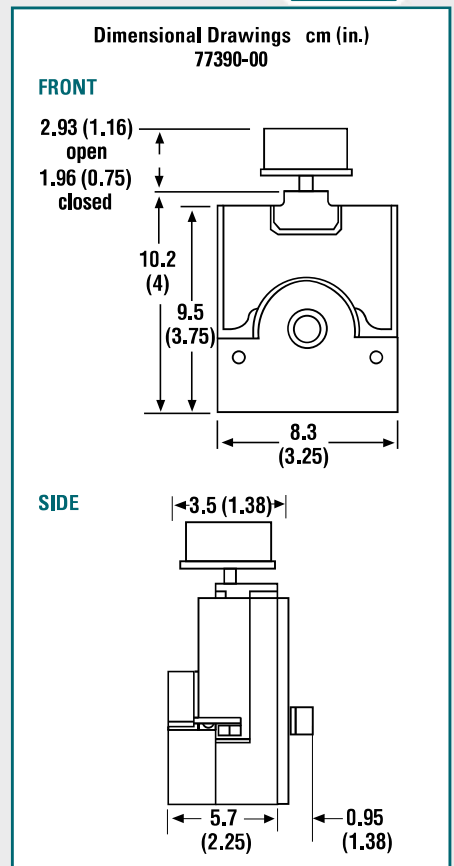

HOW TO LOAD YOUR PUMP HEAD



1. Rotate locking ring then rotate the knob on top of the pump counterclockwise. Lift occlusion bed by sliding it out the front of the body assembly.



2. Install the PTFE tubing assembly in the occlusion bed groove.



3. Slide the occlusion assembly back onto the body assembly and tighten knob.

L/S® TUBING 68–73
L/S® DRIVES 74–107
L/S® PUMP SYSTEMS 108–117

ACCESSORIES 160–171

TECHNICAL DATA 172–206